

RAY-BAR ASTRAGAL FOR PAIR DOORS

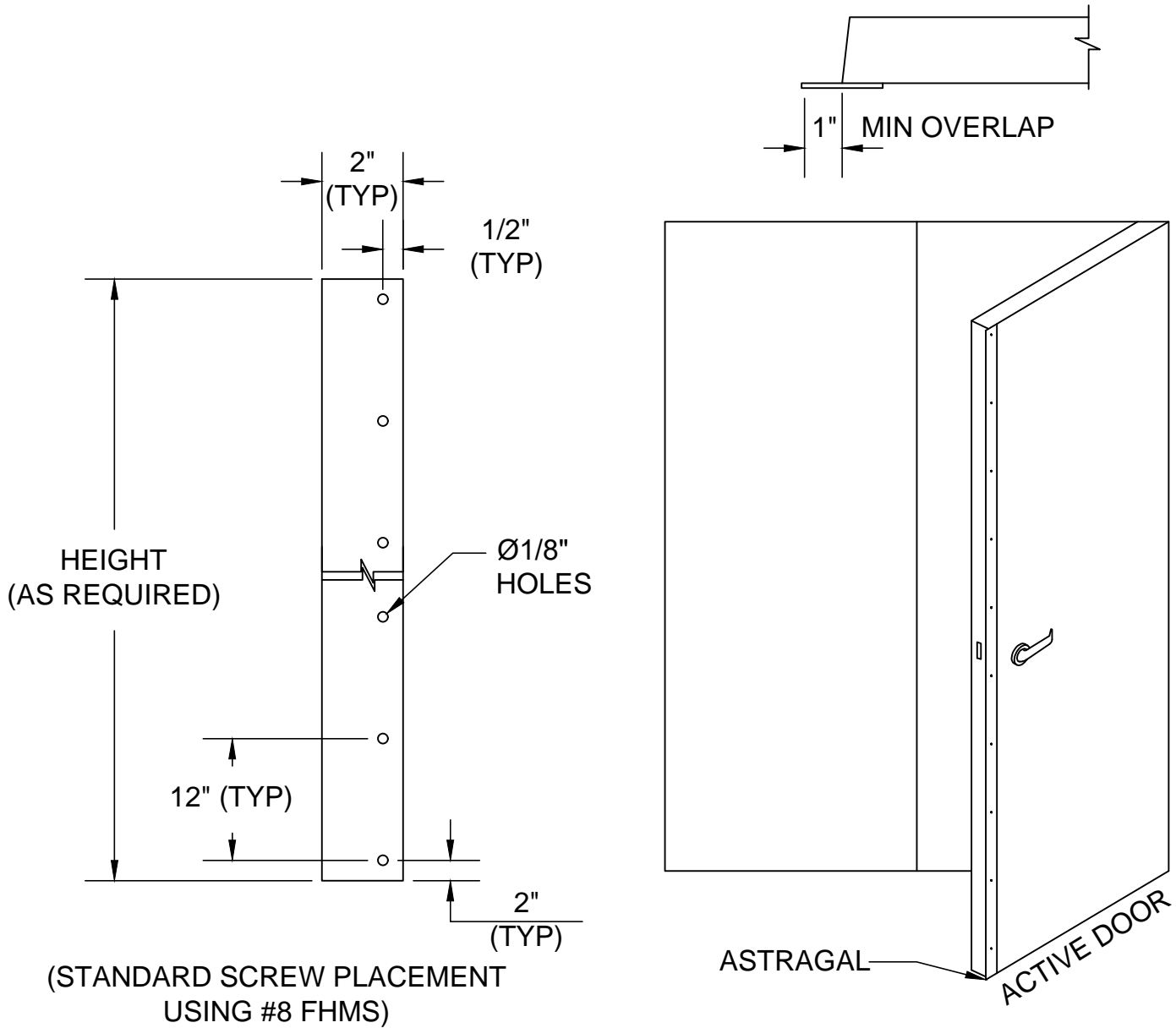

ASTRAGAL FINISHES

- PRIMERED GALVANIZED STEEL
- BRUSHED STAINLESS STEEL
- CLEAR ANODIZED ALUMINUM

PERFORMANCE OPTIONS

- FIRE RATED
- RADIATION SHIELDED
- BALLISTIC RESISTANT

UL FIRE RATINGS PER UL 10C

- METAL DOORS UP TO 3 HOURS (180 MINS)
- WOOD/PLASTIC/COMPOSITE DOORS UP TO 1-1/2 HOUR (90 MINS)
- WOOD CORE DOORS UP TO 20 MINUTES

Terms of Use: Certain designs and concepts are the exclusive proprietary property and work product of Ray-Bar Engineering provided in good faith as a courtesy for the architectural design of projects specifying, incorporating and utilizing genuine Ray-Bar products and assemblies. Ray-Bar designs are not to be copied, altered, plagiarized or utilized in any competitive or detrimental manner against Ray-Bar as protected by law and/or copyrights. "All Rights Reserved"

	JOB NAME:
	LOCATION:
	ROOM NUMBER:
	SHEET ____ OF ____:
RAY-BAR ASTRAGAL DETAIL	

RAY-BAR ENGINEERING CORP. Toll Free: 1(800) 444-XRAY / 1(800) 444-9729 Telephone: (626) 969-1818 24 Hour Fax: 1(800) 333-XRAY / 1(800) 333-9729 website: www.raybar.com		SCALE NTS ASTRAGAL 1
--	--	--------------------------------